

Buffer tanks for storage

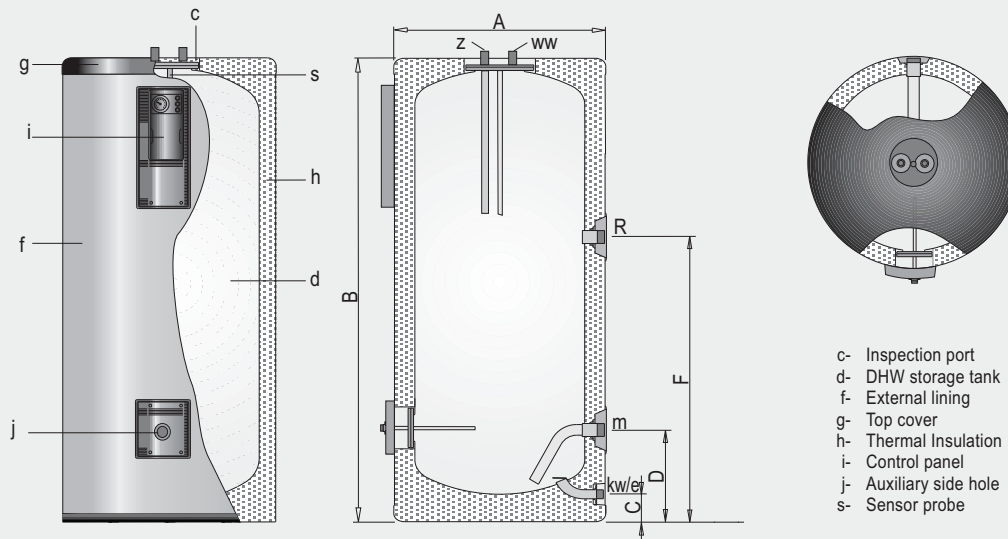

GX-200...500-R-I models

Description:

Tanks for the production and storage of domestic hot water or cold water, with capacities of 200, 300 and 500 litres

Made in AISI-316 stainless steel, chemically descaled and passivated after assembly.

Thermally insulated with CFC-free, mould-injected, 45 Kg m³ density rigid polyurethane foam.

The tank is designed for the production of domestic hot water by means of a plate heat exchanger and/or electric heating element housed in the auxiliary side hole.

The tank includes a thermometer for the DHW.

Supply:

The tank is supplied totally finished, tested and with all of its components mounted.

The external finish is with padded lining in RAL 9016 white (other optional colours are RAL 2004 orange, RAL 5015 blue or RAL 7042 grey) and covers in RAL 7021 anthracite grey.

The unit is packed in a reinforced cardboard box and strapped on a non-return wooden pallet.

Technical characteristics / Connections / Dimensions		GX-200-R-I	GX-300-R-I	GX-500-R-I
DHW capacity	litres	200	300	500
Maximum temperature of DHW tank	°C	90	90	90
Maximum pressure of DHW tank	MPa (bar)	0.8 (8)	0.8 (8)	0.8 (8)
Empty weight (approx.)	Kg	50	64	102
kw/e: Cold water inlet / Drain	"GAS/M	1	1	1
ww: DHW outlet / P&T valve connection	"GAS/M	1	1	1
z: Recirculation	"GAS/M	1	1	1
m: Side connection	"GAS/M	1-1/4	1-1/4	1-1/4
R: Side connection	"GAS/M	2	2	2
P&T relief valve size	"GAS/M	3/4	3/4	3/4
Dimension A: External diameter	mm	620	620	770
Dimension B: Total length	mm	1205	1685	1690
Dimension C:	mm	70	70	70
Dimension D:	mm	310	310	355
Dimension F:	mm	530	1015	970

Buffer tanks for storage

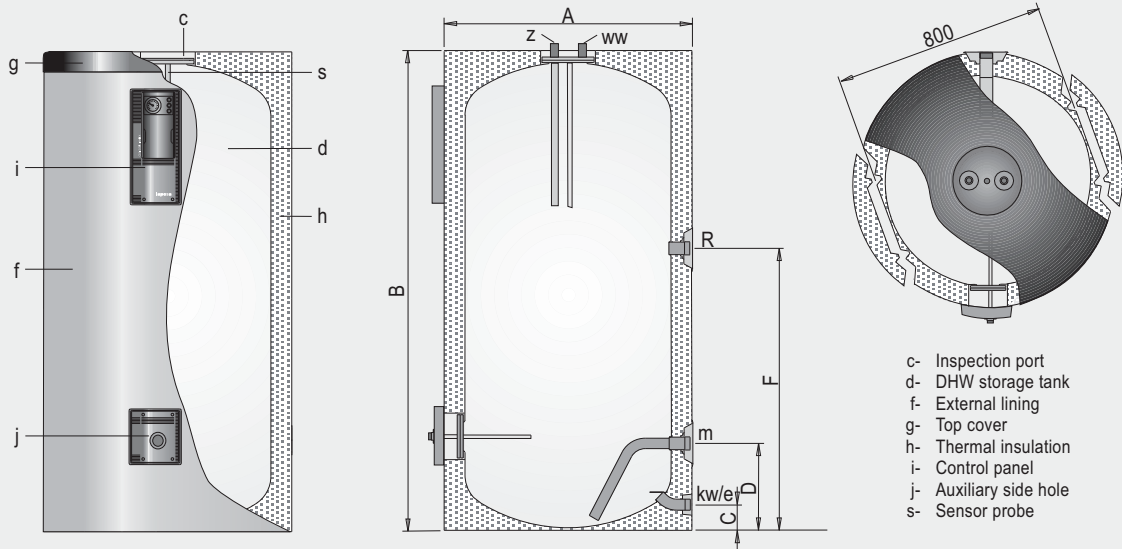

- c- Inspection port
- d- DHW storage tank
- f- External lining
- g- Top cover
- h- Thermal insulation
- i- Control panel
- j- Auxiliary side hole
- s- Sensor probe

Description:

Tanks for the production and storage of domestic hot water or cold water, with capacities of 800 and 1,000 litres

Made in AISI-316 stainless steel, chemically descaled and passivated after assembly.

Thermally insulated with CFC-free, mould-injected, 45 Kg/m³ density rigid polyurethane foam.

The tank is designed for the production of domestic hot water by means of a plate heat exchanger and/or electric heating element housed in the auxiliary side hole.

Hydraulic connections are placed on the side of the tank in order to facilitate installation. Its special design also allows the thermal insulation on the sides to be removed, allowing the tank to pass through places with limited access (800 mm).

The tank includes a thermometer for the DHW.

Supply:

The tank is supplied totally finished, tested and with all of its components mounted.

The external finish is with padded lining in RAL 9016 white (other optional colours are RAL 2004 orange, RAL 5015 blue or RAL 7042 grey) and covers in RAL 7021 anthracite grey.

The unit is packed in a reinforced cardboard box and strapped on a non-return wooden pallet.

Technical characteristics / Connections / Dimensions

		GX-800-R-I	GX-1000-R-I
DHW capacity	litres	800	1000
Maximum temperature of DHW tank	°C	90	90
Maximum pressure of DHW tank	MPa (bar)	0.8 (8)	0.8 (8)
Empty weight (approx.)	Kg	147	170
kw/e: Cold water inlet / Drain	"GAS/M	1-1/4	1-1/4
ww: DHW outlet / P&T valve connection	"GAS/M	1-1/4	1-1/4
z: Recirculation	"GAS/M	1-1/4	1-1/4
m: Side connection	"GAS/M	1-1/2	1-1/2
R: Side connection	"GAS/M	2	2
P&T relief valve size	"GAS/M	1-1/4	1-1/4
Dimension A: External diameter	mm	950	950
Dimension B: Total length	mm	1840	2250
Dimension C:	mm	100	100
Dimension D:	mm	330	330
Dimension F:	mm	1070	1480

Buffer tanks for storage with DN400 manhole

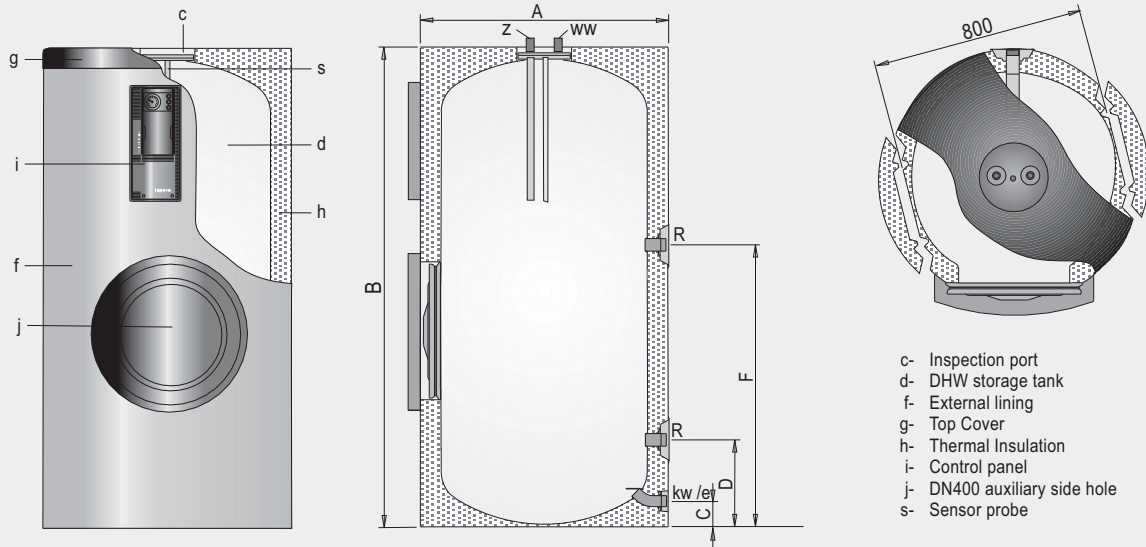

GX-800 and 1000-RB-I models

Description:

Tanks for the production and storage of domestic hot water or cold water, with capacities of 800 and 1,000 litres

Made in AISI-316 stainless steel, chemically descaled and passivated after assembly.

Thermally insulated with CFC-free, mould-injected, 45 Kg/m³ density rigid polyurethane foam.

The tank is designed for the production of domestic hot water by means of a plate heat exchanger and/or electric heating element housed in the threaded side connections.

The hot water outlet and recirculation connections are placed on the side of the tank in order to facilitate installation. Its special design also allows the thermal insulation on the sides to be removed, allowing the tank to pass through places with limited access (800 mm.)

The tank includes a thermometer.

Supply:

The tank is supplied totally finished, tested and with all of its components mounted.

The external finish is with padded lining in RAL 9016 white (other optional colours are RAL 2004 orange, RAL 5015 blue or RAL 7042 grey) and covers in RAL 7021 anthracite grey.

The unit is packed in a reinforced cardboard box and strapped on a non-return wooden pallet.

Technical characteristics / Connections / Dimensions		GX-800-RB-I	GX-1000-RB-I
DHW capacity	litres	800	1000
Maximum temperature of DHW tank	°C	90	90
Maximum pressure of DHW tank	MPa (bar)	0.8 (8)	0.8 (8)
Empty weight (approx.)	Kg	178	224
kw/e: Cold water inlet / Drain	"GAS/M	1-1/4	1-1/4
ww: DHW outlet / P&T valve connection	"GAS/M	1-1/4	1-1/4
z: Recirculation	"GAS/M	1-1/4	1-1/4
R: Side connection	"GAS/M	2	2
P&T relief valve size	"GAS/M	1-1/4	1-1/4
Dimension A: External diameter	mm	950	950
Dimension B: Total length	mm	1840	2250
Dimension C:	mm	100	100
Dimension D:	mm	330	330
Dimension F:	mm	1070	1480